

## X-ray Diffraction on High-Temperature Liquids: Evolution Towards Time-Resolved Studies<sup>1</sup>

L. Hennet,<sup>2,3</sup> S. Krishnan,<sup>4,5</sup> A. Bytchkov,<sup>2</sup> T. Key,<sup>4</sup> D. Thiaudière,<sup>6</sup>  
P. Melin,<sup>2</sup> I. Pozdnyakova,<sup>2</sup> M.-L. Saboungi,<sup>7</sup> and D. L. Price<sup>2,8</sup>

---

The use of containerless techniques enables studies of materials above the melting point and in the supercooled state with a high degree of control. In particular, the atomic structure of liquid materials can be determined by measurements of the X-ray structure factor  $S(Q)$  and calculation of the corresponding pair correlation function  $g(r)$ . At high temperature, it is useful to reduce the acquisition times in order to avoid sample deterioration or instabilities. To do that, different solutions can be used: use of a conventional detector at a third generation source, which provides intense X-ray beams leading to reduced acquisition times, use of image-plate scanners which enable short counting times with good statistics, and use of a wide-angle position-sensitive detector which is better for time-resolved studies. We show that these three approaches are complementary for studies at high temperatures.

---

**KEY WORDS:** detectors; high temperature; levitation; liquids; X-rays.

---

<sup>1</sup> Paper presented at the Seventh International Workshop on Subsecond Thermophysics, October 6–8, 2004, Orléans, France.

<sup>2</sup> CNRS-CRMHT, 1D avenue de la Recherche Scientifique, 45071 Orléans cedex 02, France.

<sup>3</sup> To whom correspondence should be addressed. E-mail: louis.hennet@cnrs-orleans.fr

<sup>4</sup> Containerless Research Inc, Evanston, Illinois 60201, U.S.A.

<sup>5</sup> Present address: KLA-Tencor Corporation, San Jose, California 95134, U.S.A.

<sup>6</sup> Synchrotron SOLEIL, L'Orme des Merisiers, BP48, 91192 Gif sur Yvette cedex, France.

<sup>7</sup> CNRS-CRMD, 1B rue de la Fêrolierie, 45071 Orléans cedex 02, France.

<sup>8</sup> Present address: HFIR Center for Neutron Research, Oak Ridge National Laboratory, Oak Ridge, Tennessee 37831, U.S.A.

## 1. INTRODUCTION

Containerless methods are useful tools for structural studies of high-temperature melts with a very high degree of control. In particular, they eliminate the problems of container interactions and contamination and the effects of the container walls on the structural measurements making it possible to access very high temperatures. An additional advantage of the containerless levitation method is that it is possible to supercool hot liquids several hundreds of degrees below their equilibrium freezing point.

Of the different containerless methods, aerodynamic levitation combined with laser heating has proved to be a powerful and versatile technique for studying the structure, dynamics and macroscopic properties of high-temperature oxide liquids [1–5].

This technique is regularly used with X-rays, and since the first X-ray study of a levitated liquid [6], various improvements have occurred. For instance, in order to avoid sample deterioration or instabilities during the measurements, developments are in progress to reduce the recording time. This can be done by different ways:

- use of third generation sources which provide X-ray beams with very high intensities,
- use of fast detectors such as image-plate scanners, which makes it possible to obtain good statistics in very short times, and
- use of wide-angle position-sensitive detectors to measure simultaneously the diffracted beam over a large Q range.

In this paper, these three options will be discussed.

## 2. TECHNICAL ASPECTS

In this paper, we present results obtained with two experimental setups. The first one has been developed by Krishnan et al. [2, 7] at Containerless Research Inc. and Argonne National Laboratory (Illinois, USA) and installed on two beamlines at the Advanced Photon Source (APS) at Argonne. The second has been developed by Hennet et al. [8] at CRMHT in Orleans (France) and mounted at the H10 beamline at LURE (Orsay, France).

### 2.1. Experimental Setup at APS

Since this setup is largely described elsewhere [2, 7], we give only a brief description of the apparatus here, as illustrated in Fig. 1.

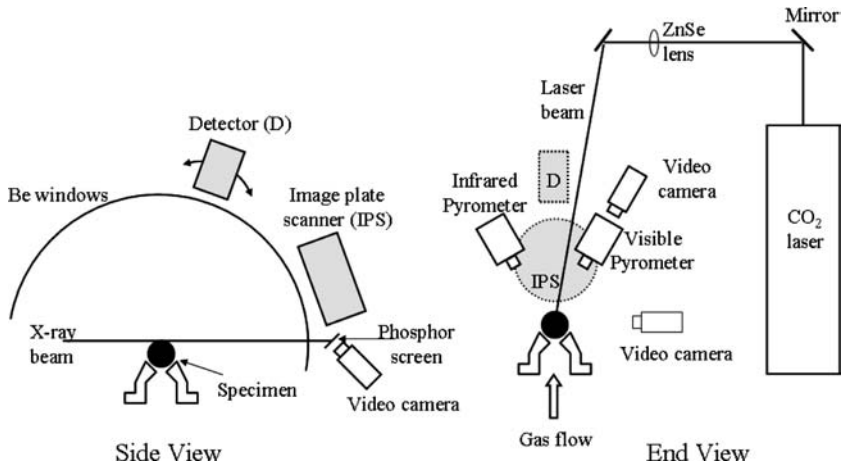

Fig. 1. Schematic view of the experimental arrangement at APS.

The levitation chamber is installed at the center of the goniometer. A spherical sample is levitated by a gas flow going through a nozzle situated in the center of the chamber. A mass flow controller enables accurate regulation of the gas flow. For experiments on liquid metals, the chamber is evacuated, purged for short durations with gas flow, and then filled with high-purity argon. A pressure regulation system maintains the chamber at a pressure around 0.5 bar. The argon gas flow is about 300 standard cm<sup>3</sup> per minute.

A 270 watt CO<sub>2</sub> laser ( $\lambda = 10.6 \mu\text{m}$ ) is used for specimen heating. The laser beam is directed at the specimen with two laser mirrors through a ZnSe window.

Two optical pyrometers are employed simultaneously. The first one operates at  $0.65 \mu\text{m}$  and the other in the  $1\text{--}2.5 \mu\text{m}$  bandpass. The pyrometers are oriented at  $45^\circ$  on either side of the vertical plane and are focused at a point on the surface of the specimen close to the illumination point of the X-ray beam.

Precise sample positioning is achieved by means of a motorized translation stage nozzle and using a phosphor screen in front of a video camera to observe the shadow of the specimen in the X-ray beam. This setup enables measurements on both liquid oxides and metals.

Depending on the beamline, the diffracted beam is detected using two types of detectors. On ID-11-C, we used a Ge solid-state detector scanned over an angular range of  $2\text{--}105^\circ$  and, on ID-11-B, a fixed image-plate scanner with a scanned area of 345 mm diameter.

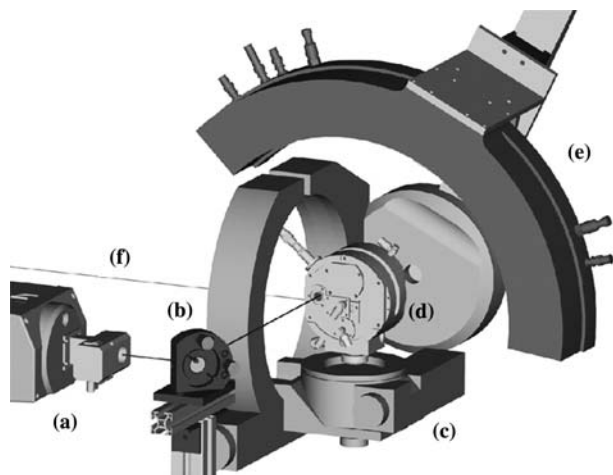

**Fig. 2.** Schematic view of the experimental arrangement at LURE: (a) laser head, (b) first mirror, (c) goniometer, (d) high-temperature chamber, (e) curved detector, and (f) X-ray beam.

## 2.2. Experimental Setup at LURE

Figure 2 is a schematic view of the experimental arrangement on the H10 beamline at LURE. A detailed description of this beamline can be found in Ref. 9. The high-temperature chamber is mounted on a 4-circle goniometer. The working principle of the high-temperature chamber is described in detail elsewhere [8]. This chamber uses the same kind of nozzle as the APS setup and the same gas-flow controllers. This setup was designed to study liquid oxides and does not have a sealed chamber. It was used at atmospheric pressure with open windows. The heating system consists of a continuous 125 W CO<sub>2</sub> laser. The primary laser beam, with a diameter of approximately 5 mm, is focused on the sample by two mirrors (one spherical and one flat) in order to obtain a final diameter of about 1 mm at the sample position. The temperature is measured with an optical pyrometer operating at a wavelength of 0.85  $\mu\text{m}$ .

The diffracted beam was measured using an INEL 120° curved detector allowing the simultaneous collection of scattered intensity over a large angular range with good statistics and in a relatively short time.

## 3. EXPERIMENTS

### 3.1. X-ray Diffraction on Liquid Boron

In this section, we present results obtained on levitated liquid boron. The melting point has been determined previously to be 2360 K [10]. There

are few experimental measurements on liquid boron due to the fact that it is extremely reactive with any container even in the high-temperature solid state. Krishnan et al. [11] performed the first X-ray study of the structure of liquid boron. This work presents good quality measurements of the structure factor  $S(Q)$  above the melting point and in the supercooled state for  $Q$  values up to  $11 \text{ \AA}^{-1}$  at an energy of about 15 keV. The aim of these new measurements was to increase the range of the scattering vector  $Q$  by using a higher energy X-ray beam.

The experiments were carried out at the 11-ID-C beamline at APS. This beamline is situated on a multipole wiggler, providing an intense X-ray beam. Scattering measurements were made at an X-ray energy of 21 keV over a  $2\theta$  angular range of  $2\text{--}105^\circ$ , corresponding to a scattering vector  $Q$  range of  $0.4\text{--}16.9 \text{ \AA}^{-1}$ .

Figure 3 presents the structure factor,  $S(Q)$ , for liquid boron measured in the normal liquid at 2500 K and in the supercooled state at 2300 K. The apparent temperatures measured by the pyrometer were corrected by using an emissivity of 0.31 determined previously by Krishnan et al. [11]. All curves are characterized by a weak first peak at approximately  $2.5 \text{ \AA}^{-1}$  followed by the main peak located at  $4.5 \text{ \AA}^{-1}$ . These curves are very similar to those obtained previously [11] but present two additional features at 12 and  $15 \text{ \AA}^{-1}$ .

Figure 4 shows the pair correlation function,  $g(r)$ , for the same temperatures. The positions of the three first peaks in  $g(r)$  are 1.76, 3.16, and  $4.64 \text{ \AA}$  at 2500 K and 1.78, 3.14, and  $4.6 \text{ \AA}$  at 2300 K. Integration under the first peak gives a coordination number for boron atoms of around six at both temperatures. From these measurements, it is not possible to confirm the decrease of the coordination number in the supercooled state as proposed in the first study [11].

For these measurements, we used a counting rate of 2 s per point with a step of  $0.25^\circ$ . This gives a global counting time of 22 min including the detector travel time. For such measurements, the minimal counting time necessary for obtaining reasonable statistics in the high  $Q$  region is 15 min (1 s per point).

### 3.2. Use of an Image-Plate Scanner

In order to further reduce the counting time, we have used an image-plate scanner at a fixed position. These experiments were carried out at the 11-ID-B beam line at APS. Scattering measurements were made at an X-ray energy of 90 keV. The large diameter of the detector (345 mm) enabled us to get a useful  $Q$  range of  $0.5\text{--}17 \text{ \AA}^{-1}$ .

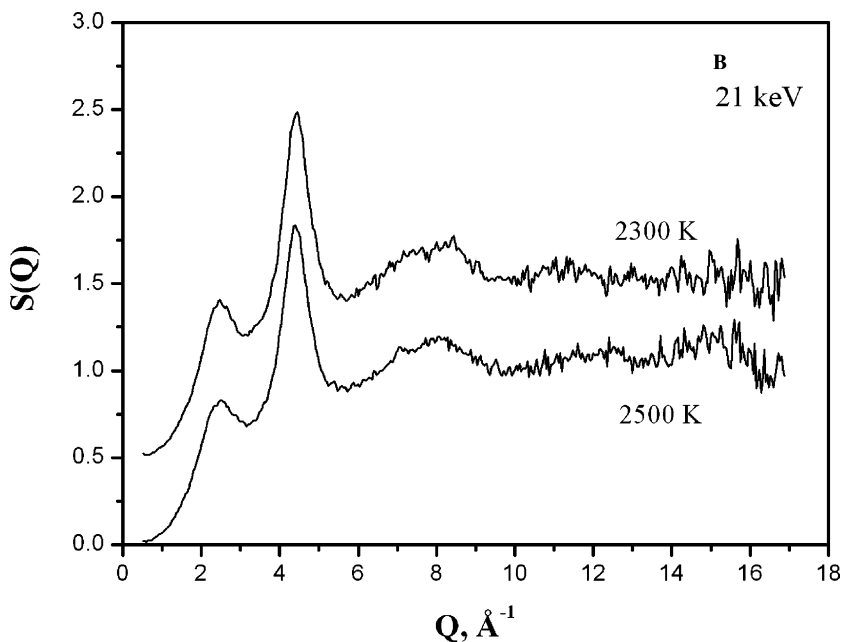

**Fig. 3.** X-ray structure factor for liquid boron at 2300 and 2500 K. Upper curve is shifted up by 0.5 for clarity.

In Fig. 5 we compare the X-ray scattered intensities  $I(Q)$  measured on liquid boron at 2300 K with the image-plate scanner and with the solid state detector described above. The total counting times were 5 and 22 min (2 s per point), respectively.

As seen from the figure, the intensities measured by the image-plate scanner are three times higher than these with the solid state detector. The statistics are considerably improved, and the noise is very small especially in the high  $Q$  region. In particular, the fourth and fifth peaks are better defined.

This shows that the use of an image-plate scanner at high energy is a very good tool for studying the liquid state with very short counting times and reasonable statistics. It provides the possibility to perform experiments on the same sample at different temperatures over a limited period.

Although it enables very fast measurements, the major drawback of this detector is the long read-out time between two measurements, a few tens of seconds. This is the time necessary to transfer the data and to erase the scanning area. It is therefore impossible to use this kind of detector to perform rapid consecutive data acquisition and to consider time-resolved measurements.

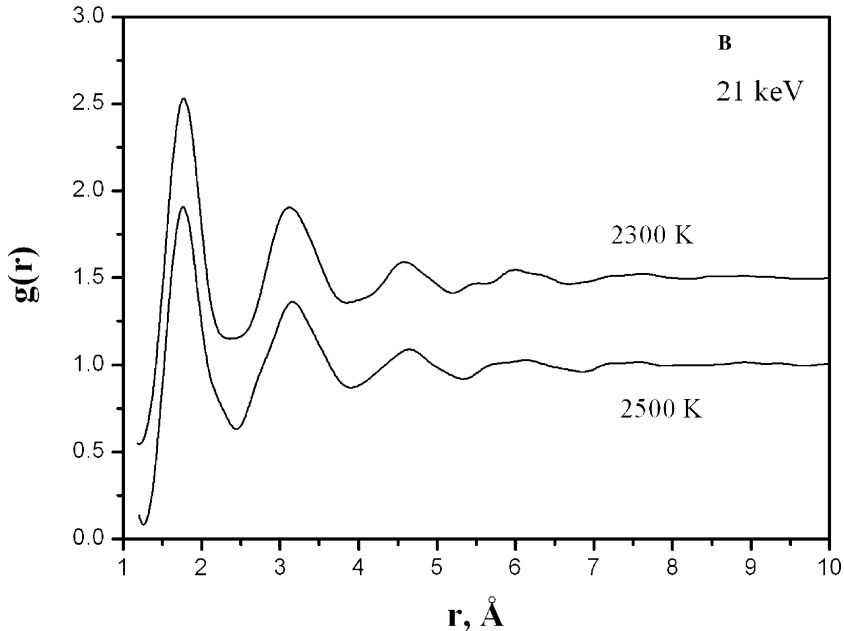

**Fig. 4.** Pair correlation function for liquid boron at 2300 and 2500 K. Upper curve is shifted up by 0.5 for clarity.

### 3.3. Fast X-ray Scattering Measurement on Liquid Yttria

As shown above, it is possible to do measurements at various temperatures on the same sample above the melting point and in the supercooled state in a relatively short time period. A new objective of this study was to make time-resolved measurements of the structural changes in a material as the liquid–solid or liquid–glass transitions are approached. Since solidification occurs very quickly after the laser shutdown (around 0.4 s), these dynamical studies require measurements of  $S(Q)$  with acquisition times less than 0.1 s

The experiments were carried out at the H10 beam line at LURE. It was not possible to work on boron due to the chamber design, so we have chosen to present results on liquid yttrium oxide. With the help of the 120° curved detector we have been able to make rapid measurements of the structure factor  $S(Q)$  of levitated  $Y_2O_3$  at 2700°C with acquisition times down to 1 s. The structure factors obtained with counting times of 1 and 300 s are shown in Fig. 6. The inset presents the corresponding pair correlation functions.

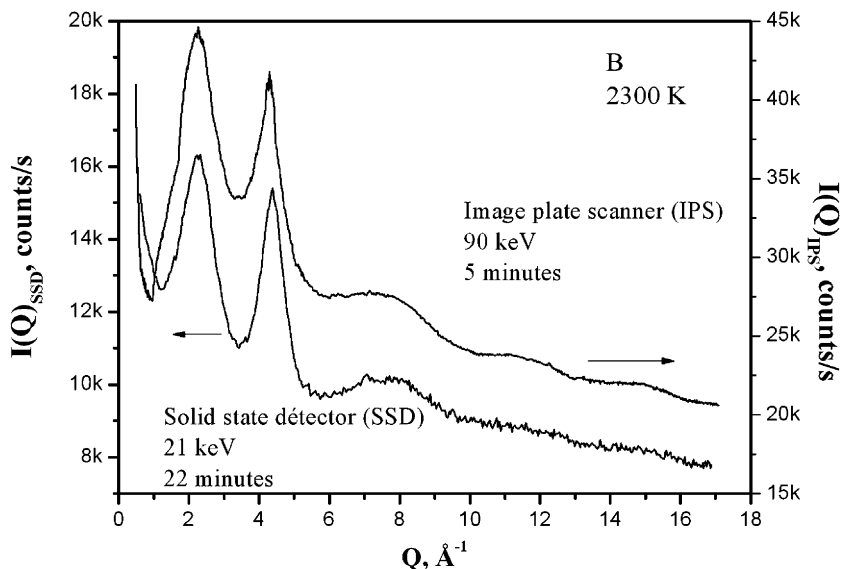

Fig. 5. Scattered intensity for liquid boron at 2300 K recorded with the image-plate scanner for 5 min and the solid state detector for 22 min.

As expected, the statistics are reduced with decreasing counting times and the noise is increased, particularly in the high- $Q$  region. Nevertheless, the relatively good agreement between the two values of  $g(r)$  shows that the data remain usable. It was not possible to go further below 1 s at LURE due to the low beam intensity, but it would be possible with a higher flux. It is a real challenge to study structural changes in liquids at sub-second time scales as the onset of solidification (crystallization or glass transition) is approached. The feasibility of such experiments has been recently demonstrated at the Synchrotron Radiation Source at Daresbury (UK) using a counting time of 0.1 s [12].

#### 4. CONCLUSION

We have used different kinds of detectors for studying liquid materials at high temperatures above the melting point and in the supercooled state.

The scanned solid-state detector gives results with a reasonable quality but requires a longer counting time. It is particularly useful for anomalous scattering measurements [13].

With the image-plate scanner, it is possible to obtain good statistics even with very short counting times. This detector is very useful to



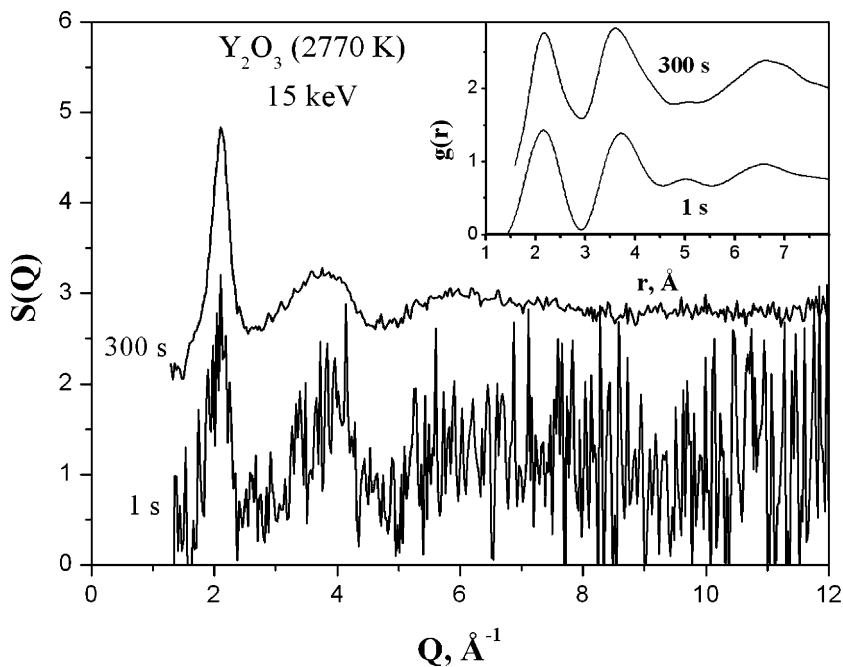

**Fig. 6.** Total structure factor  $S(Q)$  for liquid yttria at 2770 K measured with counting times of 1 and 300 s. Inset represents the corresponding pair correlation functions. Upper curves have been shifted up for clarity.

perform studies at various temperatures in a limited period. Nevertheless, the long read-out time of this detector makes it unsuitable for real-time measurements.

With a wide angle position-sensitive detector, it is possible to perform consecutive data acquisitions with very short times. Used on high flux sources, this kind of detector enables time-resolved studies with counting times of less than 0.1 s.

The combination of all three approaches will be very powerful for characterizing the structure of liquid materials at high temperature, including the supercooled state and approaching the solidification regime.

## ACKNOWLEDGMENTS

The authors wish to thank M.Beno, J. Linton and G. Jennings of the APS for their guidance and help with the experiments. The work was supported by the "Conseil Regional du Centre", the CNRS and the NASA Microgravity Sciences and Applications Division, under Grant No.

NAS8-00122. APS is supported by the US Department of Energy under Contract No. W31-109-ENG-38.

## REFERENCES

1. D. Massiot, D. Trumeau, B. Touzo, I. Farnan, J. C. Rifflet, A. Douy, and J.-P. Coutures, *J. Phys. Chem.* **E99**:16455 (1995).
2. S. Krishnan and D. L. Price, *J. Phys.: Condens. Matter* **12**:R145 (2000).
3. L. Hennet, D. Thiaudière, C. Landron, J.-F. Bézar, M.-L. Saboungi, G. Matzen, and D. L. Price, *Nucl. Instrum. Methods Phys. Res. B* **207**:447 (2003).
4. L. Hennet, D. Thiaudière, C. Landron, P. Melin, D. L. Price, J. P. Coutures, J.-F. Bézar, and M.-L. Saboungi, *Appl. Phys. Lett.* **83**:3305 (2003).
5. H. Sinn, B. Glorieux, L. Hennet, A. Alatas, M. Hu, E. E. Alp, F. J. Bermejo, D. L. Price, and M. L. Saboungi, *Science* **299**:2047 (2003).
6. S. Ansell, S. Krishnan, J. K. R. Weber, J. J. Felten, P. C. Nordine, M. Beno, D. L. Price, and M. L. Saboungi, *Phys. Rev. Lett.* **78**:464 (1997).
7. S. Krishnan, J. J. Felten, J. E. Rix, J. K. R. Weber, P. C. Nordine, M. A. Beno, S. Ansell, and D. L. Price, *Rev. Sci. Instrum.* **68**:3512 (1997).
8. L. Hennet, D. Thiaudière, M. Gailhanou, C. Landron, J. P. Coutures, and D. L. Price, *Rev. Sci. Instrum.* **73**:124 (2002).
9. M. Gailhanou, J. M. Dubuisson, M. Ribbens, L. Roussier, D. Bétaille, C. Créoff, M. Lemonnier, J. Denoyer, C. Bouillot, A. Jucha, A. Lena, M. Idir, M. Bessière, D. Thiaudière, L. Hennet, C. Landron, and J. P. Coutures, *Nucl. Instrum. Methods Phys. Res. A* **467–468**:745 (2001).
10. S. Krishnan, P. C. Nordine, J. K. R. Weber, and R. A. Schiffman, *High Temp. Sci.* **31**:45 (1991).
11. S. Krishnan, S. Ansell, J. J. Felten, K. J. Volin, and D. L. Price, *Phys. Rev. Lett.* **81**: 586 (1998).
12. O. Majerus et al., to be published.
13. K. Suzuya, D. L. Price, M.-L. Saboungi, and H. Ohno, *Nucl. Instrum. Methods. Phys. Res. B* **133**:57 (1997).